



# GTC 80

# GTC 80

GTC 80 is versatile drilling machine designed for both professional and personal use.

Its robust chassis and components are mounted on caterpillar tracks, ensuring mobility and stability across various terrains.

The machine is powered by a reliable Briggs & Stratton engine.

### Area of use:

- Water wells
- Geothermal drilling
- Geotechnical drilling
- Sampling
- DTH (Down-The-Hole) drilling



# Technical specification

## SPECIFICATION

## GTC 80

Rotary head torque	850 Nm
Rotary head RPM	60
Max pull up force	1500 kg
Max pull down force	900 - 1500 kg
Water swivel head	Yes
Pipe feed lenght	1.5 m
Max drilling depth	80 m
Maks. drilling diameter	200 mm
Power supply	Gasoline
Engine power	14 HP EFI Vanguard
Mast slide Travel	400 mm
Stabilization	3 Cylinders with block valves

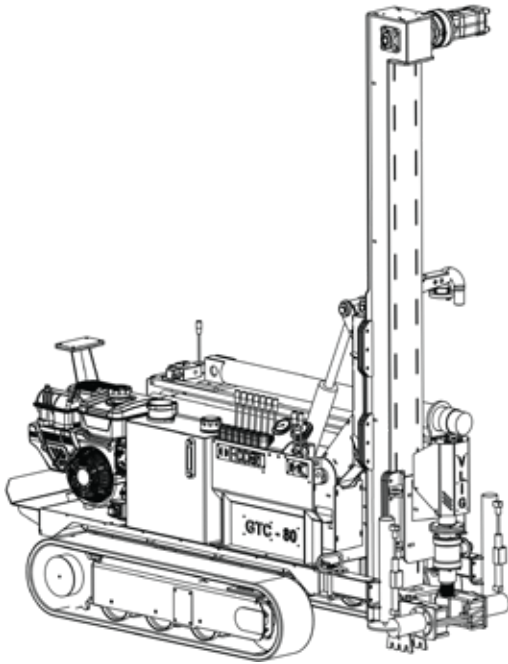

### SIDE VIEW - TRANSPORT

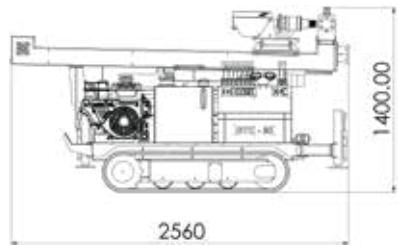

### BACK VIEW - MIN HEIGHT

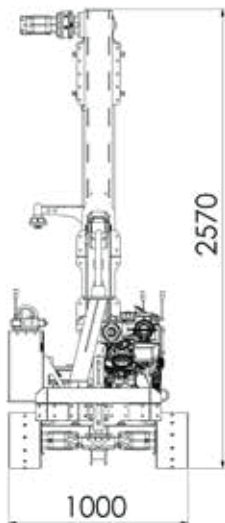

### SIDE VIEW - MAX HEIGHT

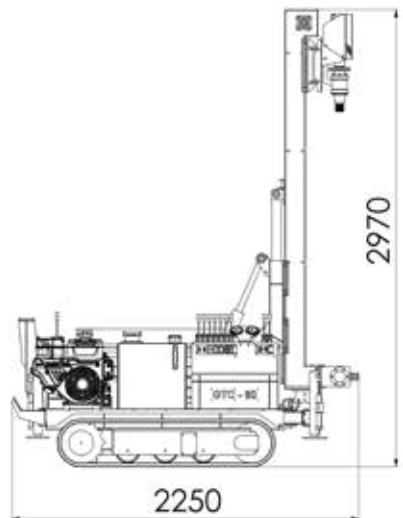

---

 Globare bb, 37257 Krusevac, Srbija

 065 5242331 / 064 0807369

 [office@vlig.rs](mailto:office@vlig.rs)

